

# A SURVEY OF TURBINE-TYPE WATER-MILLS IN THE BOLU REGION OF THE CENTRAL ANATOLIAN PLATEAU<sup>1</sup>

H.H.Günhan DANIŞMAN

Received February 12, 1977.

1. This article was originally submitted to the University of London as part of a Ph.D. Thesis on the history of (building) technology in Anatolia: see, G. DANIŞMAN, "Timber Building Activity on the Anatolian Plateau and its Conservation" Ph.D. Thesis, University of London, August, 1976.

2. The first major study on this subject was the first Volume of: R. BENNETT and J. ELTON, *History of Corn Milling*, London, 1898; also see, L. LINDET, *Les origines du moulin à grains*, *Revue archéologique*, Paris, 1899, t.II et 1900 t.I.

3. V.G. CHILDE, *Rotary Querns on the Continent and in the Mediterranean Basin*, *Antiquity*, Newbury, Berkshire 1943, v.XVII, pp. 19-26; C.E. CURWEN, *Querns*, *Antiquity*, Newbury, Berkshire 1937, v. XI, pp. 133-51; C.E. CURWEN, *More About Querns*, *Antiquity*, Newbury, Berkshire 1941, v.XV, pp. 15-32; and, C.E. CURWEN, *The Problem of Early Water Mills*, *Antiquity*, Newbury, Berkshire, 1944, v.XVIII, pp. 130-46.

4. H.E. WULFF, *The Traditional Crafts of Persia*, London; M.I.T. Press, 1966, pp. 277-91.

5. K. HODGES, *Technology in the Ancient World*, New York: Alfred A. Knopf, 1970, pp. 224-31; and, K. WILLIAMSON, *Horizontal Water-Mills of the Faeroe Islands*, *Antiquity*, Newbury, Berkshire, 1946, v. XX, pp. 83-91.

6. C.E. CURWEN, *A Vertical Water-mill near Salonika*, *Antiquity*, Newbury, Berkshire, 1945, v.XIX, pp. 211-12 and plates iii-iv.

7. M.T. HODGEN, *Domesday Water Mills*, *Antiquity*, Newbury, Berkshire, 1939; v. XIII, pp. 261-79.

## INTRODUCTION

The problem of early water-mills, both as important implements of food production on a commercial or industrial scale for urban cultures, as distinct from individual food production instruments of peasant cultures, and in their impact as a revolutionizing advancement in technology, in the form of the rotary mill in which the first major application of rotary motion has taken place since the invention of the potter's wheel and the lathe during the Bronze Ages of the Near East, has preoccupied the scholars of ancient technology since the end of the last Century.<sup>2</sup> During the 1930s and the 1940s, important contributions have been made by the British archaeologists in an attempt to bridge the gap of archaeological evidence as to the origins of water-mills,<sup>3</sup> while the only reliable ethnographical information from the Near East with regards to Persian examples has not appeared until quite recently.<sup>4</sup> Further ethnographical examples have been illustrated from Scandinavia,<sup>5</sup> and from Mainland Greece,<sup>6</sup> and an impressive study of the distribution of over 5600 Domesday water-mills have been made for England.<sup>7</sup> Evidence from Anatolia, on the other hand, has not been forthcoming, neither in the form of ethnographical examples, nor as archaeological evidence, except for a remarkable discovery of a late Roman or early Byzantine mosaic from Istanbul depicting a water-mill<sup>8</sup>. This situation has been tried to be remedied, at least for a part of the Anatolian Plateau, during a study conducted in the Bolu Region on early timber technology and vernacular timber building activity.<sup>9</sup> Numerous examples of turbine-type water-mills, employing a highly skilled timber technology and indicating an unparalleled concentration of ethnographical examples of a basically Roman type vertical-shaft mill in a relatively small area, have been studied and recorded.

## AREA OF FIELD STUDY

The field study was conducted in the area to the east of the Principality of Bolu along the small river valleys lying between the town of Gerece and the city of Bolu (Figure 1). All

Fig. 1 A Distribution Map of Water-Mills in Bolu Region.

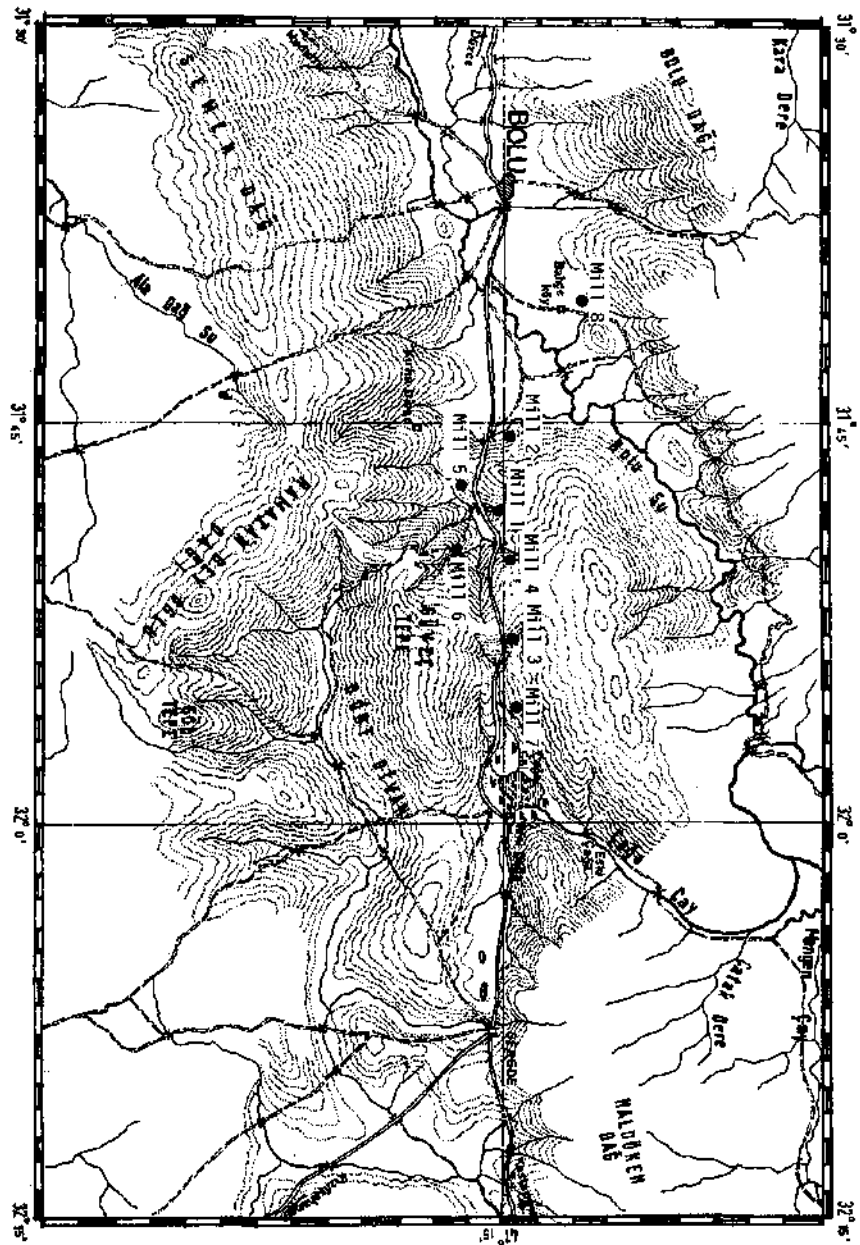

8. A detail of the mosaic which has been discovered by the Walker Trust (St. Andrews University) excavations in the Great Palace of Byzantium and dated to the early fifth century has been depicted as being the only example of a water-mill in late Roman art. The importance of the mosaic stems from the fact that references to water-mills are rare in Roman literature. Furthermore, this lack of literary record is repeated by a corresponding lack of evidence for actual mills from excavations. From the fourth century onwards, however, evidence from both literary sources and excavations become more plentiful. The early Byzantine mosaic from Istanbul, therefore, gains a crucial importance as a first-hand pictorial evidence. It is apparent that the mill illustrated in this mosaic is the type described by Vitruvius in the 1st century B.C. in which the water passed below the wheel, striking the blades to make it rotate, and the millstone made to work through a gear system very similar to that used in the water-raising wheel. However, the position of the wheel as depicted in this mosaic is rather curious, and leaves much doubt as to the actual design of the mill-house with relation to the positioning of the water-wheel (Figure 2). For further information, refer to: G. BRETT, *Byzantine Water-mill, Antiquity*, Newbury, Berkshire, 1939, v.XIII, pp. 354-56 and plate vii; also see: H. HODGES, *Technology in the Ancient World*, New York: Alfred A. Knopf, 1970, pp. 230-31 and Figure 224.

9. I am grateful to Prof. Henry HODGES of the Art Conservation Program at Queen's University, Kingston, Ontario, Canada, and formerly of the University of London, for his invaluable guidance in directing my field research on the Anatolian Plateau towards uncovering ethnographical evidence on turbine-type water-mills with an attempt to bridge the gap in our knowledge in this respect. The field research reveals only a partial picture for the Bolu Region, let alone for the rest of the Anatolian Plateau, and there is ample evidence that early water mills are fast falling into disuse or disappearing totally, which indicates the need for further research as soon as possible.

The examples that were studied were of a single type, i.e. the vertical-shaft and horizontal-wheel (or the water-turbine type) mills. Out of 12 mills surveyed, only 3 were operational. The rest have fallen into disuse and disrepair, abandoned probably during the last decade owing to the increase in industrialized flour production in the region.

The alarmingly large number of abandoned mills indicates how vulnerable the ethnographical evidence on early technology is in most areas of the Anatolian plateau. The need is, therefore, obvious for further and immediate research in this field.

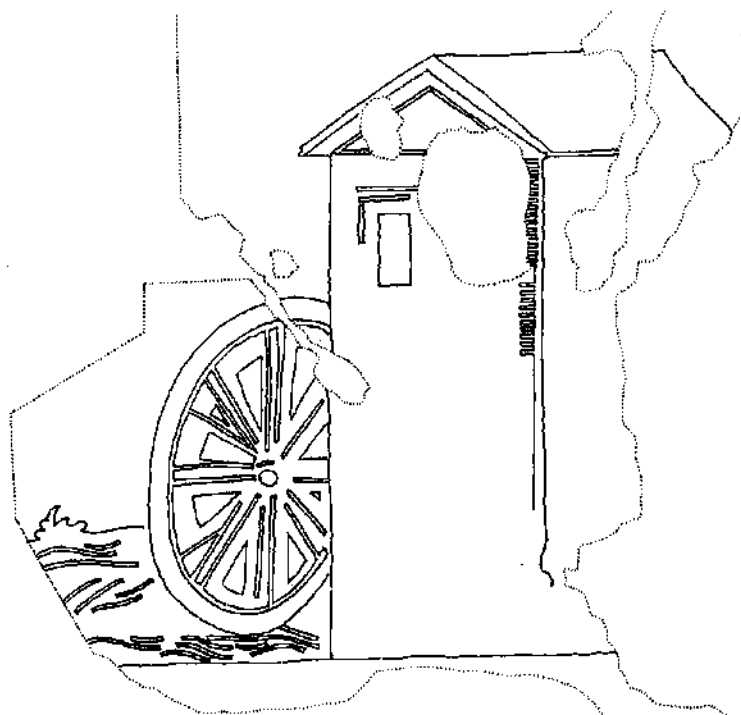

Fig. 2 Early fifth century mosaic from the great palace of Byzantium. (Sketch after: G. BRETT, *Byzantine Water-mill*, *Antiquity*, 1939, *sl.*, v. XII, plate VII following p. 366.)

## THE PRESENT STATE OF KNOWLEDGE ON PREHISTORY AND HISTORY OF FLOUR MILLING

It has been suggested that the two established groups of terminology in European languages used to designate the implements of producing flour, namely the various derivatives of the Latin word *mola* or *molina*, which also include the English *mill*, and the north European family of words that closely resemble the English word *quern*, essentially signify the same concept and can, therefore, be used interchangeably.<sup>10</sup> The first distinction that needs to be made in the developmental sequence of flour milling is between hand-operated mills and those mills employing an inanimate power such as water or wind. The later type of mills are a direct development from rotating hand-mills or rotary-querns, which form one of the two main classes of hand-mills, the other being non-rotating hand-mills.<sup>11</sup> Non-rotating hand-mills can be classified into three sub-groups:

- a) mortars,
- b) grain-rubbers, and
- c) saddle-querns.

The mortars consist of the use of a stone or any other type of pestle to pound roots or grains in a natural or artificial rock-basin, and it is believed that they go back to Palaeolithic times.<sup>12</sup> Its use still continues in many primitive societies for pounding food stuffs as well as for other objects like dyes for painting purposes or for production of various additives used in pottery making such as pumice powder, etc., (Figure 3) Grain-rubbers were basically a specialized type of mortar suited to the grinding, rather than pounding, of small grains. This was effected by making the stone basin wide and shallow, like a saucer, while the pestle became squat and bun-shaped, so that it could be held in one hand and swept around and round the lower stone, or to-and-fro in any direction (the

10. See Dr. Curwen's discussions on the philology of querns in: C.E. CURWEN, *More About Querns*, *Antiquity*, Newbury, Berkshire, 1941, v. XV, pp. 31-32.

11. C.E. CURWEN, *Querns*, *Antiquity*, Newbury, Berkshire, 1937, v. XI, p. 194.

12. C.E. CURWEN, *Querns*, *Antiquity*, Newbury, Berkshire, 1937, v. XI, p. 134.

13. C.E. CURWEN, Querns, *Antiquity*, Newbury, Berkshire, 1937, v.XI, p. 135.

14. C.E. CURWEN, Querns, *Antiquity*, Newbury, Berkshire, 1937, v.XI, p. 137.

15. V.G. CHILDE, Rotary Querns on the Continent and in the Mediterranean Basin, *Antiquity*, Newbury, Berkshire, 1943, v.XVII, p. 19; also see: R.J. FORBES, Food and Drink, *A History of Technology*, v. II, Ed. by C. Singer et al., Oxford: The Clarendon Press, 1957, pp. 103-12; and, R.J. FORBES, Power, *A History of Technology*, v. II, Ed. by C. Singer et al., Oxford: The Clarendon Press, 1957, pp. 589-622.

16. C.E. CURWEN, Querns, *Antiquity*, Newbury, Berkshire, 1937, v.XI, pp. 137-38.

17. V.G. CHILDE, Rotary Querns on the Continent and in the Mediterranean Basin, *Antiquity*, Newbury, Berkshire, 1943, v. XVII, p. 23.

18. V.G. CHILDE, Rotary Querns on the Continent and in the Mediterranean Basin, *Antiquity*, Newbury, Berkshire, 1943, v. XVII, p. 23.

19. C.E. CURWEN, Querns, *Antiquity*, Newbury, Berkshire, 1937, v.XI, p. 138.

20. H. HODGES, *Technology in the Ancient World*, New York: Alfred A. Knopf, 1970, p. 224.

pushing-mill probably originated from this).<sup>13</sup> Saddle-querns, on the other hand, are believed to have developed from grain-rubbers by gradual stages, in which the lower stone takes saddle shape while upper stone is bolster-shaped and grinding is effected by a to-and-fro movement with both hands (Figures 4 and 5).

Although the origins of the rotating hand-mills or rotary-querns are obscured,<sup>14</sup> their importance, nevertheless, from the technological point of view with regards to being the first major application of rotary motion, other than the potter's wheel and lathe, can not be overstressed.<sup>15</sup> Scholars of ancient technology have tended to declare the principle of revolving mill as a great advancement which could not have become possible by the normal process of development.<sup>16</sup> Invention is dated to 5th Century B.C., and the home of invention is attributed to either west-central Mediterranean,<sup>17</sup> Palestine,<sup>18</sup> mainland Greece,<sup>19</sup> or Asia Minor.<sup>20</sup>

It is certain that archaeological evidence for early use of rotary querns in Greece is not conclusive, and their use has

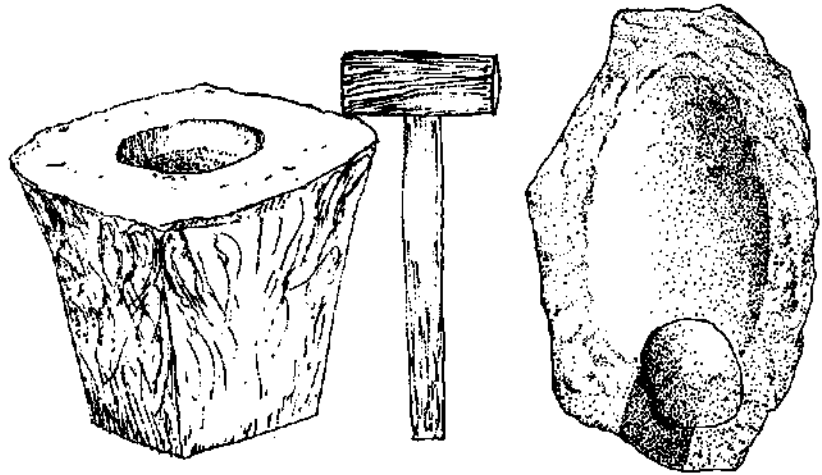

Fig. 3 A classical column capital converted to be used as mortar, with its wood pounder, at Bahçeköy village in Bolu Region of the Central Anatolian Plateau

Fig. 4 A grain-rubber from Egypt; before 4000 B.C. (After: H. HODGES, *Technology in the Ancient World*, New York: Alfred A. Knopf, 1970, p. 34, Fig. 22.)



Fig. 5 A model from Egypt showing a saddle quern type hand-mill in use; before 2000 B.C. (After: H. HODGES, *Technology in the Ancient World*, New York: Alfred A. Knopf, 1970, p. 35, Fig. 23)

21. V.G. CHILDE, "Rotary Querns on the Continent and in the Mediterranean Basin", *Antiquity*, Newbury, Berkshire, 1943, v. XVII, p. 19.

22. V.G. CHILDE, *Rotary Querns on the Continent and in the Mediterranean Basin*, *Antiquity*, Newbury, Berkshire, 1943, v. XVII, pp. 24-25; also see Prof. Childe's references to passages in Xenophon's *Cyropaedia*, H.G. DAKYNS, (Trans.), *The Works of Xenophon*, v. II. London: Macmillan and Co., 1890, Chap. vi, Para. 2, p. 31.

23. V.G. CHILDE, *Rotary Querns on the Continent and in the Mediterranean Basin*, *Antiquity*, Newbury, Berkshire, 1943, v. XVII, p. 25.

24. C.E. CURMEN, *Querns*, *Antiquity*, Newbury, Berkshire, 1937, v.XI, p. 25.

25. For the Pompeian example, refer to: R.J. FORBES, *Food and Drink, A History of Technology*, v.II, Ed. by C.Singer et al., Oxford: The Clarendon Press, 1957, Fig.77, p. 110; and for the Ostian example, refer to: H.HODGES, *Technology in the Ancient World*, New York: Alfred A. Knopf, 1970, fig. 217, p. 225.

26. R.J. FORBES, *Food and Drink, A History of Technology*, v. II, Ed. by C. Singer et al., Oxford: The Clarendon Press, 1957, p. 110.

remained somewhat rare until the 3rd Century B.C. However, the available evidence suggests that from Greece this type of mill spread as far north as the Alpine region, and into the area of the Celtic La Tène Iron Age civilization of 1st Century B.C., by which it reached Southern England towards the end of the same century.<sup>21</sup> The spread of the classical portable rotary hand-mill with its two flat stones seems closely connected with the movement of the armies of Greece and Rome.<sup>22</sup> The role of the merchant ship as another distributive agent for the diffusion of this type of hand-mills has also been pointed out, for ships must have carried portable mills for grinding grain on long voyages.<sup>23</sup>

Existence of the donkey-driven mills in Greece, side by side with the rotary hand-mill, has been suggested on the basis of some literary evidence,<sup>24</sup> though archaeological evidence supporting this assumption has been rather scarce. However, Roman examples of donkey-mills making use of the suitably hard Vesuvian lava exist, for example at Pompeii (A.D.79) and at Ostia.<sup>25</sup> As possible origins to this type of grain-mill, it has been suggested that it may have been derived from similar contrivances used in the 5th and 4th centuries B.C. for crushing ore in the silver mines at Laurion.<sup>26</sup> Such a mill consisted of a lower stone, *meta*, in the form of a cone with an angle as much as 35 or 40 degrees, the apex of which carried the iron spindle which supported the upper stone, *catillus*, in order to prevent the mill-stones from contributing stone-grit to the flour, in the similar manner of a spindle provided to the developed rotary-quern (Figures 6 and 7). The upper stone consisted of a hollow cone, or sometimes two hollow cones

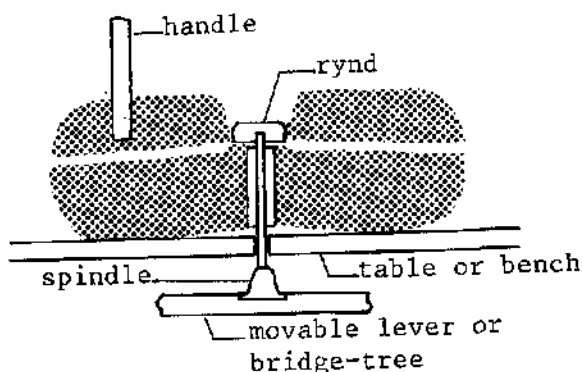

Fig. 6 A contemporary Scottish rotary-quern. (After: C.E. CURMEN, *Querns*, Newbury, Berkshire, v. XI, 1937, p. 146, Fig. 39.)

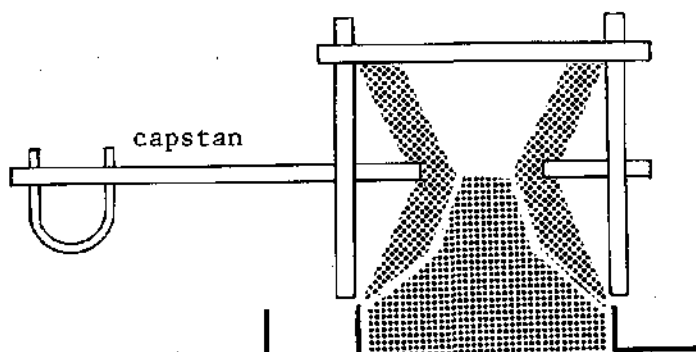

Fig. 7 Diagram showing how a donkey driven mill operated. (After: H.HODGES, *Technology in the Ancient World*, New York: Alfred A. Knopf, 1970, p. 225, Fig. 218.)

placed apex to apex, with one fitted over the conical lower stone, while the other served as a hopper into which the grain was thrown. An iron bridge, called in English the *rynd*, was placed across the narrowest part of the opening between the two hollow cones, and rested on top of the spindle. The upper stone was turned by means of two large horizontal levers set in sockets on its sides, and other animals like mules and horses as well as donkeys were harnessed to the spokes, or even slaves were used.

What is most significant is that the development of rotary-mill led on directly to the invention of the water-wheel, or more precisely to water-turbine, employing for the first time inanimate motive power in the form of jets channeled from fast-flowing streams and directed onto the blades of the horizontally set turbines, which in turn rotated the upper mill-stones via their vertical axes that passed through the lower mill-stones without any gearing. The development of vertically-set water-wheels, working on the principles of water flowing beneath the wheel, in which the rotary motion is transferred to the upper mill-stone through the use of geared machinery seems to be a more complicated technological advancement than the 'water-turbine', and on the face of the available evidence a later development in time. However, it is not certain whether the vertical water-wheel was developed from the horizontal water-wheel, or not. It has been suggested, on the other hand, that the system of vertical water-wheel mills show a strong resemblance in design to the water-raising wheels,<sup>27</sup> believed to have been in use in Egypt for some centuries before the first appearance of this type of water-mills, in which a draught animal working through a capstan rotated a wheel bearing cups at its rim, each cup dipping into the river and being discharged into a chute a little more than a half-turn of the wheel. It becomes obvious at this point that there was a close relationship between the type of water-wheel and the level and speed of the river water. For example, the vertical water-wheel had its limitations in that it was

27. H. HODGES, *Technology in the Ancient World*, New York: Alfred A. Knopf, 1970, p. 229.

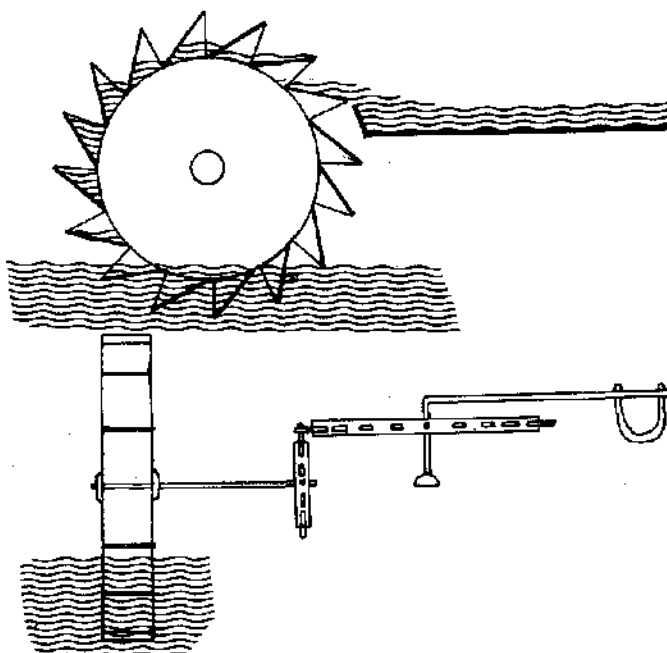

Fig. 8 Diagram showing how the water raising wheel operated. (After: H.HODGES, *Technology in the Ancient World*, New York: Alfred A. Knopf, 1970, p. 226, Fig. 219.)

28. H. HODGES, *Technology in the Ancient World*, New York: Alfred A. Knopf, 1970, p. 229.

dependent for its proper functioning on a level flow of water in the river, and the functioning of the wheel would be hindered if the river was in spate or too low. Thus, a few centuries later around about 5th Century A.D., a third type of water-wheel has appeared, i.e. the overshot wheel in which the water, ponded back in a mill pond was directed by means of a chute over the top of the water-wheel.<sup>28</sup> The result of this development was that by controlling the level of the water in the mill pond by means of sluices, the water-mills could be made to function at most seasons of the year throughout most of the Roman Empire, and that a technology inherited by Romans was further developed by the application of the ingenuity of Roman engineering so that the spread of water-mill throughout the Empire as an essential prerequisite of their urban culture was accomplished (Figures 8, 9 and 10).

It is quite clear that the jump from the rotating hand-mills, or the rotary-querns of animate power, such as donkey-mills, to the use of first water-powered mills, through the use of water-turbines, is a most important and crucial technological advancement in the ancient world.

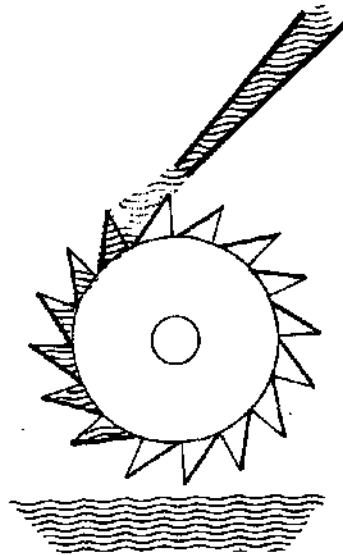

Fig. 9 Diagram showing the principle of overshot wheel.  
(After: H.HODGES, *Technology in the Ancient World*, New York: Alfred A. Knopf, 1970, p. 231, Fig. 226.)

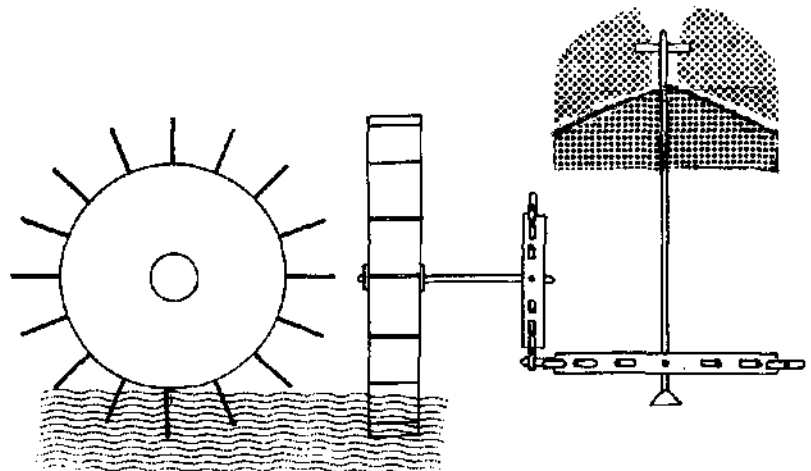
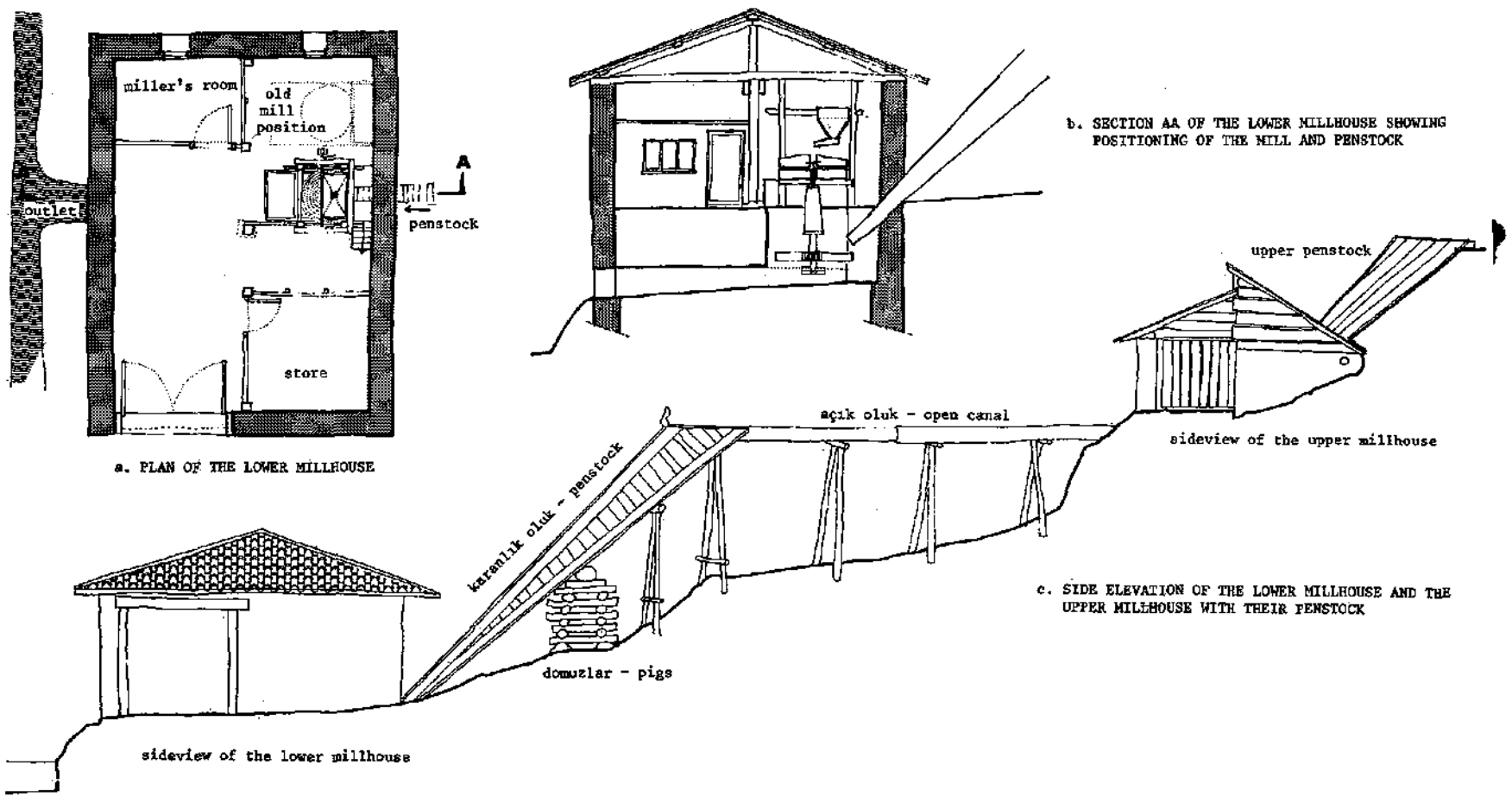

Fig. 10 Diagram showing how the vertical water-wheel (Vitruvian) mill operated.  
(After: H.HODGES, *Technology in the Ancient World*, New York: Alfred A. Knopf, 1970, p. 230, Fig. 225.)

Fig. 11 Drawing of Gaur'un Bagirmani (Water-mill Number 1)



a. PLAN OF THE LOWER MILLHOUSE

b. SECTION AA OF THE LOWER MILLHOUSE SHOWING POSITIONING OF THE MILL AND PENSTOCK

c. SIDE ELEVATION OF THE LOWER MILLHOUSE AND THE UPPER MILLHOUSE WITH THEIR PENSTOCK



## DESCRIPTION OF WATER MILLS IN THE BOLU REGION

All the mills that have been studied within the survey area of the Bolu Region were of water-turbine type, i.e. mills with horizontal water-wheels and vertical axles. Out of eight mills, five were found abandoned and in a state of gross neglect and disrepair. The implications of abandoned mills will be discussed briefly in the section dealing with problems of conservation. The two operational mills that will be discussed here are called *Gavur'un Değirmeni*, which will be designated as water-mill No.1, and *Murat'ın Değirmeni* at Kirha Village, which will be designated as water-mill No. 2 from now on.

## a. Water-mill No. 1 - GAVUR'UN DEĞİRMENİ

It is quite clear from the physical planning and the topographical positioning of this mill that from its inception it has been intended to be a multiple mill using a single source of water (Figure 11). The mill presently consists of two separate mill-houses, the lower mill-house with a single operational water-wheel arrangement and with its own penstock (Figures 12 and 13), and an upper mill-house which is now disused but again with its own penstock (Figure 14), both built on a series of man-made



Fig. 12 *Gavur'un Değirmeni* (Water-mill Number 1) : Lower mill-house.

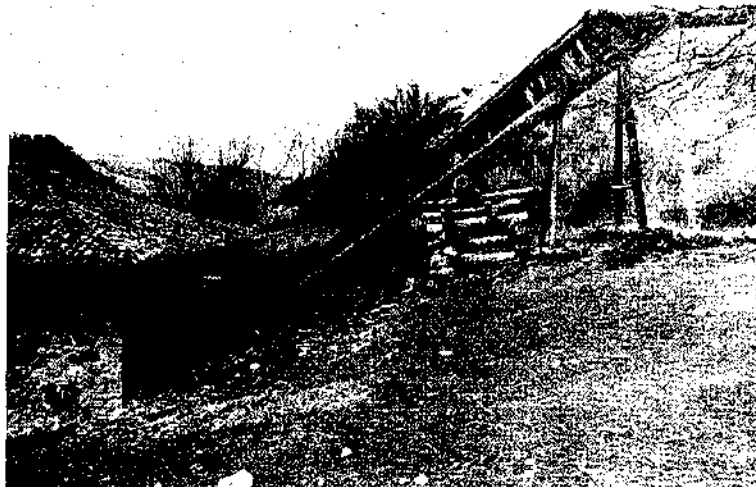

Fig. 13 *Gavur'un Değirmeni* (Water-mill Number 1) : Lower penstock.



Fig. 14 Gavr'un Değirmeni (Water-mill Number 1) : Upper penstock.

terraces. The whole complex is approached via a timber foot-bridge giving access, over a fast-flowing stream, from the main thoroughfare running along this valley between the towns of Bolu and Gerece, an arrangement repeated at other mills as well, e.g. at the abandoned mill No. 4. The main source of water is directed to the mill at the highest level within what looks like a natural open-canal (Figure 15). At the head of this canal is positioned a timber lock-system, with three separate outlets, one for the upper penstock, one for the lower penstock, and one for the diversion-canal to redirect the continuous flow of water to the stream at the bottom of the valley (Figure 16). Although the actual detailing of each penstock differ somewhat, they seem to follow the same general principles in their design and construction, in that the directing of water into the chute of the penstock to create the necessary strength of potential energy for the rotation of the water-turbine entails in each case an open-timber-canal carved out of a single tree trunk (Figures 11 and 14) usually carried by a series of timber-posts and supports (Figure 11), and then a closed penstock supported by a distinctive timber-footing employing logs laid at right angles to each other, also known as pigs (Figures 13 and 14). The actual design of the upper penstock consists of large planks laid horizontally along the length of the penstock and groove-jointed to each other, while held in position by a series of timber bracelet-frames employing keyed mortice-and-tenon joints, the purpose of all being to avoid the use of any form of iron spikes or nails completely (Figure 14). The lower penstock, on the other hand, actually considerably longer than the upper penstock, is constructed by employing four very long horizontal beams at each corner of the penstock running along the length of it, to which are pegged vertical boards on the inner face for side elevations, while similar boards are pegged on the outside faces of the top and bottom surfaces lying along the width of the penstock (Figures 11 and 13). These two designs seem to be prototypes for all the timber penstocks that were studied in the Bolu Region, one suitable for longer water heads while the other for comparatively short falls. In each case the slope



Fig. 15 The open canal.

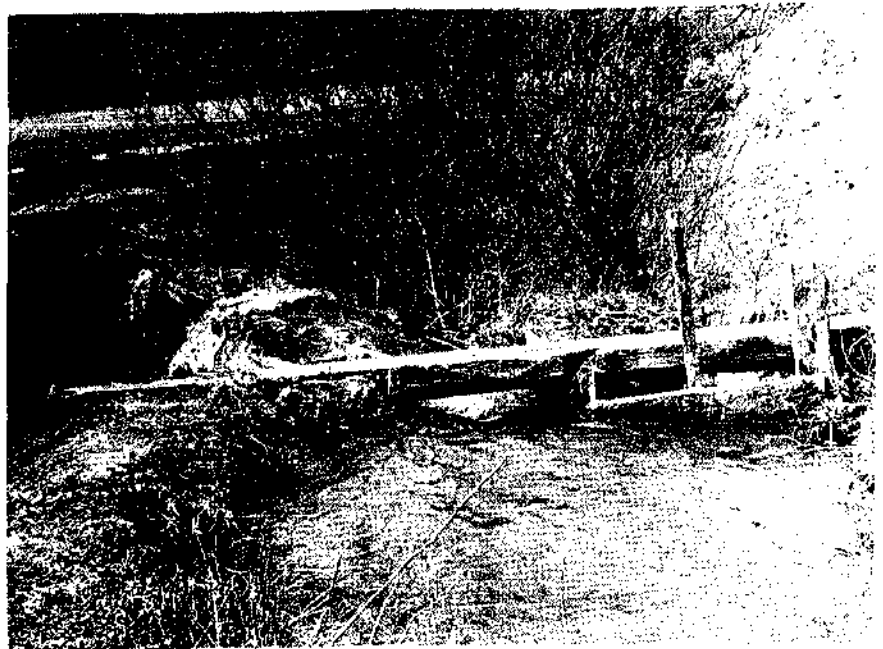

Fig. 16 The timber lock system.

is calculated between 30 and 40 degrees. The interior of the upper mill-house was found inaccessible, however, the interior of the lower mill-house, both with regards to its large size and due to the positioning of its single mill, indicated that there might previously have been one, or even two more water-wheels in use (Figure 11). The construction of each mill-house, on the other hand, was similar, with a substructure of common rough uncoursed-rubble, i.e. random-stone walls carrying a timber superstructure protected by a roof-covering of 'Anatolian pantiles'. The shape of lower roof was hipped, while the upper roof was gabled, both having a rather rough and unrefined structure. For all purposes of construction throughout the mill, various types of locally available softwood timbers have been used. The detailed set-up of the water-wheel arrangement, which follows the same general principle in every

mill-house, will be described when the interior features of Mill No. 2, which are found to be more characteristic, will be outlined.

b. Water-mill No. 2 - MURAT'IN DEĞİRMENİ at Kırha Village

The external arrangements of mill No. 2 follows closely the general pattern of most other mills in this area, except that in this case the water is pooled in a small pond in spite of a continuous flow of water, which is believed to be for the purpose of dividing the available water into three separate penstocks for three mill positions on the interior, each of which was operational at the time of the field survey. The description of different elements which compose the mill on the interior can best be effected in three parts. Firstly, the upper section includes the *hopper*, the *feeder-channel*, the *oscillator* that keeps the feeder-channel operating, the *warning-bell* mechanism that begins to operate as grain in the hopper is decreased, and a *regulator* that controls the flow of grain (Figures 17 and 18). Secondly, the middle section includes the *mill-stones*, which are usually produced from a special coarse sandstone with or without a limestone content, and with the rotating upper-stone termed as the *runner* and the stationary lower stone termed as the *bed-stone*, the metal *rind* which is carried on the end of the rotating *spindle*, usually again of metal, and is inserted into a groove cut into the runner to rotate and support it, and the *lower-hopper* or *flour-bin* into which the ground flour is collected (Figure 17). The mill-stones are usually surrounded by *wooden-hoops* or *iron-bands* around their circumference, in order to keep the ground flour together during operation of the rotating stone and lead it into the lower-hopper, as well as to protect the fast running stones (average speed 60 to 120 r.p.m.) from breaking. The average diameter of stones vary between 100 to 110 cm, and the initial height is about 20 cm with an average of about 3 operational-years life-span for the runner, after which it becomes, according to the information supplied by the millers, too thin to be used without the danger of breaking. And finally, the lower-house section of the mill's set-up consists of the *water-wheel* or the *turbine*, with the *turbine-blades* set at an angle to face the jet of water most effectively, the *shaft* or *axle* which is fixed to the centre of the wheel and rotates with it without the need for any gear mechanism and into which the spindle is positioned, the *wheel-bed* or the *bearing-block* on which the wheel and the metal *pivot-pin* that fits the lower end of the wheel axle rests, the *shutter* for regulating the water flow and thus stopping the wheel, the *lever* or *sword* which is attached to the wheel-bed and used for the adjustment of the runner or the upper-stone in order to obtain the required flour grade in the milling process, and lastly, the *chute* or the mouth of the penstock which progressively tapers from a large cross-section at the top of the water-fall to a small bore of about 10 cm in diameter in order to produce a strong water jet at an eccentric or oblique position over the turbine (Figures 17 and 18). In addition to these three basic sections there are some supplementary equipment at each mill position, such as a raised platform that the miller uses when he is topping up the hopper with grain (Figure 17), and a primitive but ingenious pulley system for holding the flour sack upright in front of the lower-hopper (Figure 19), which is obviously designed as a labour-saving device for the miller, who works

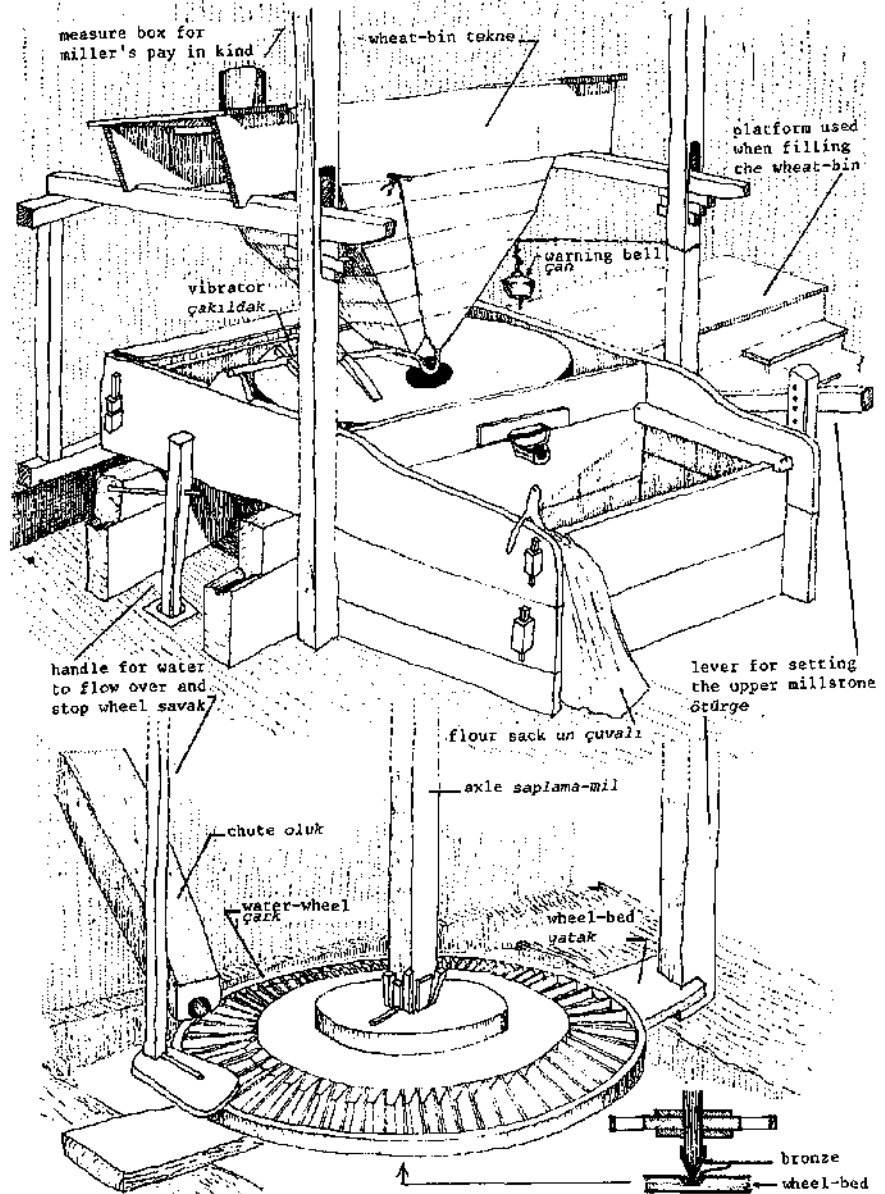

Fig. 17 Drawing of the interior of *Mızrat'ın Değirmeni* (Water-mill Number 2 at Kirha).

alone and usually with several mill-positions operating simultaneously.

The components of the first two sections of the mill arrangement described above do not differ for any of the three types of water-mills, namely the horizontal water-wheel type, the vertical water-wheel type, and the floating-wheel type. The components of the third section, however, have to be altered for the vertical water-wheel type mill and the floating-wheel type mill in order to accommodate a geared machinery necessary to transmit the rotary motion to the upper mill-stone.

#### NOMENCLATURE PROBLEMS OF THE WATER-MILLS

The three different types of water-mills are known by various names. The earliest type with horizontal water-wheel, besides

29. C.E. CURWEN, *The Problem of Early Water-Mills, Antiquity*, Newbury, Berkshire, 1944, v. XVIII, p. 130.
30. R.J. FORBES, *Power, A History of Technology*, Ed. by C. Singer et al., Oxford: The Clarendon Press, 1957, p. 593.
31. R.J. FORBES, *Power, A History of Technology*, Ed. by C. Singer et al., Oxford: The Clarendon Press, 1957, p.607.
32. R.J. FORBES, *Power, A History of Technology*, Ed. by C. Singer et al., Oxford: The Clarendon Press, 1957, p.607.
33. For the Shetland words, refer to: C.E. CURWEN, *The Problem of Early Water-Mills, Antiquity*, Newbury, Berkshire, 1944, v.XVIII, p. 141; and for the Persian words, refer to: H.E. WULFF, *The Traditional Crafts of Persia*, London; M.I.T. Press. 1966, pp. 277-83.

being called as the 'turbine' type, is also known as the 'vertical' mill,<sup>29</sup> or as the Greek or the Norse mill.<sup>30</sup> The second type with a horizontal shaft to the vertically set water-wheel is also known as the Vitruvian mill,<sup>31</sup> due to its association with the 1st Century B.C. Roman Engineer Vitruvius who illustrated and described this mill in his books. The third type of mills, the floating-mill, was developed as a result of invention of paddle-wheels employing fast moving waters of the rivers.<sup>32</sup>

A comprehensive glossary of the essential components of the turbine type water-mill in various languages is given below<sup>33</sup> (Figure 20) :

<u>English</u>	<u>Shetland</u>	<u>Turkish</u>	<u>Persian</u>
1. Hopper	Hopper	Tekne	Dul
2. Feeder-channel	Shoe	Küçük-tekne	Hâvdân
3. Oscillator	Clapper	Çakıldak	Saitânak
4. Rind or Rynd	Sile	Baltacık	Beleşkeh
5. Runner or upperstone	Overstane	Üst değirmen-taşı	Sang-e nar
6. Bed-stone or lowerstone	Understane	Alt değirmen-taşı	Sang-e zir
7. Spindle	Spindle	Mil	Mil-e āhani
8. Shaft or axle	Tirl	Saplama	Mil
9. Water-wheel or turbine	-	Çark	Çarh
10. Blades or paddles	Feathers	Çark-dişleri or kulakları	Par-vane
11. Pivot-pin	Gudgeon	Kama	Mih
12. Wheel-bed or bearing-block	Sole-tree	Yatak	Tahteh
13. Lever or sword	-	Savak	Pars-dār
14. Chute	Trough	Oluk	
15. Penstock	-	Kanal	Tanur

## CONSERVATION PROBLEMS OF WATER-MILLS IN THE BOLU REGION

In the case of operational water-mills, it is obvious that the miller would be seeing to the day to day maintenance of his mill-house and the various components of his mill machinery. In fact, this situation was confirmed in those water-mills that were operational in the Bolu Region. Field investigation by the writer has also indicated that there are still a few mill-wrights in the local villages to take care of the more substantial repair works, although it was discovered that no new apprentices are being trained and theirs is a dying craft. Furthermore, a disused, or abandoned water-mill is immediately prone to deterioration, starting with the wooden parts that have been in constant contact with water until the mill has fallen into disuse. This situation is explicitly illustrated in the abandoned mill No. 3 (Figures 21, 22 and 23), where the open timber canal, the penstock, and the water-wheel have suffered considerably as a result of sudden over-drying of timbers that have been constantly in contact with water throughout their operational lives. Especially the penstock, the detailing of which is similar to the lower penstock of mill No. 1, has badly deteriorated as a result of pegged joints decaying and causing

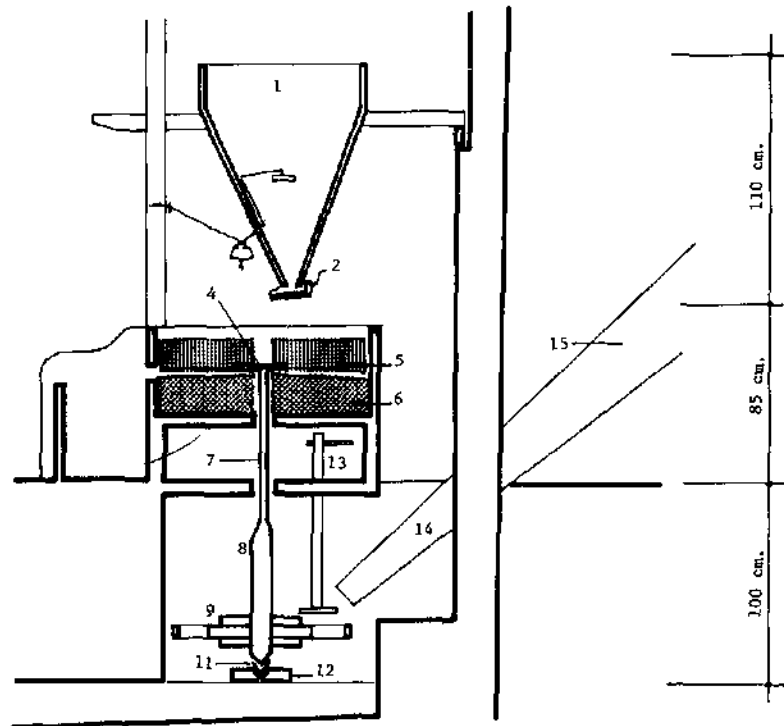

Fig. 18 Basic elements of a typical turbine-type mill on Anatolian Plateau (Bolu Region).

further structural failure. This particular problem is also apparent in the abandoned mill No. 4. Here, the pen-stock of a design resembling the upper penstock in mill No. 1 has structural problems due to loosening of the keyed mortice-and-tenon jointed bracelet-frames around the penstock, as well as deterioration of timbers due to excess shrinkage and defibration (Figure 24 and 25). This situation seems to be further complicated as a result of alternating rainy and dry periods where these timbers exposed to the atmospheric conditions suffer further swelling and shrinkage in constant succession, and in which cases of excessive warping and cracking were also observed. The mill-houses were also found to be in gross state of neglect. The roof timbers as well as the floor beams supporting the mill-stones and separating the under-house from the ground floor area were partially collapsed in abandoned mill No. 4, while the mill-house has completely disappeared in the abandoned mill No. 5, except for some remains of stone substructure and remnants of the penstock and its timber footing. The degeneration of penstocks was also observed, where indigenous timber penstocks and footings have been replaced either by stone and concrete, or structures built of metal sheeting and disused oil barrels, as illustrated in the abandoned mill No. 6 (Figure 26). These degenerate forms of repair and replacement further indicate the importance of conserving the more valuable examples of traditional methods of construction and examples of the mill-wright's craft in this part of the Anatolian Plateau.

#### IMPLICATIONS OF DETERIORATION OF WATER-MILLS AND A SUGGESTION FOR THE IMPLEMENTATION OF A CONSERVATION SCHEME

The analysis of deteriorating examples of turbine type water-

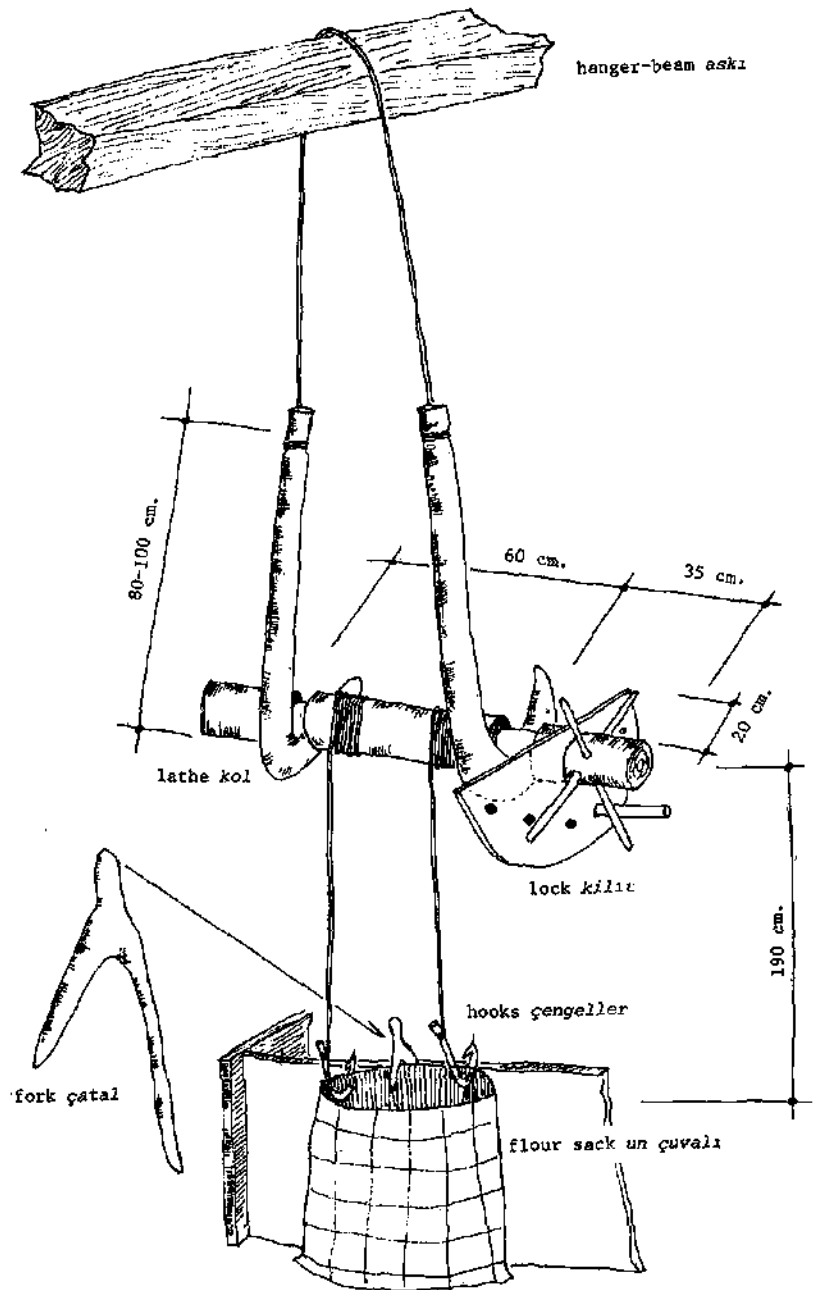

Fig. 19 Details from *Murat'ın Değizmeni*  
(Water-mill Number 2).

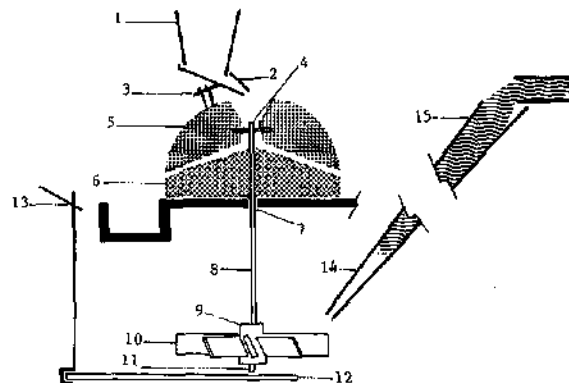

Fig. 20 Diagram showing how the horizontal  
mill operated, based on a  
contemporary Norwegian example.  
(After: H. HODGES, *Technology in  
the Ancient World*, New York:  
Alfred A. Knopf, 1970, p. 228,  
Fig. 223.)



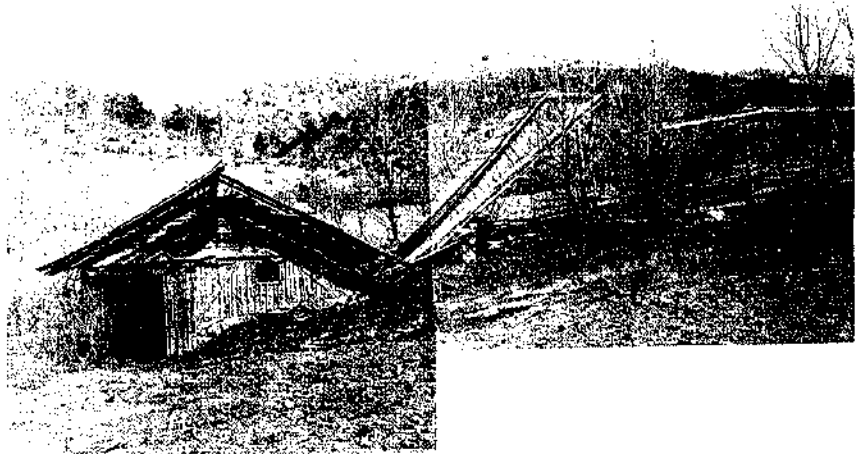

Fig. 21 The abandoned mill Number 3.  
General view.

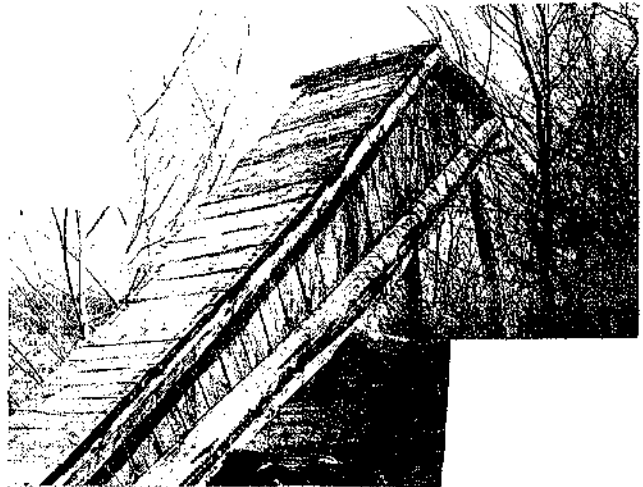

Fig. 22 The abandoned mill Number 3. The  
penstock

mills in the Bolu Region of the Anatolian Plateau indicates that particularly difficult problems of timber conservation are created as soon as a mill is abandoned, for instance the need for treating large sections of waterlogged wood *in situ*, or consolidation of severe cases of shrinkage and defibration, again with the timbers in position, may become inescapable. Also special treatments may become necessary for the deterioration of metal parts of the mill's components, as well as the regular maintenance of movable parts of the machinery to keep the mill operational.

It is obvious that economic pressures of industrialized flour



Fig. 23 The abandoned mill Number 3. The open canal.

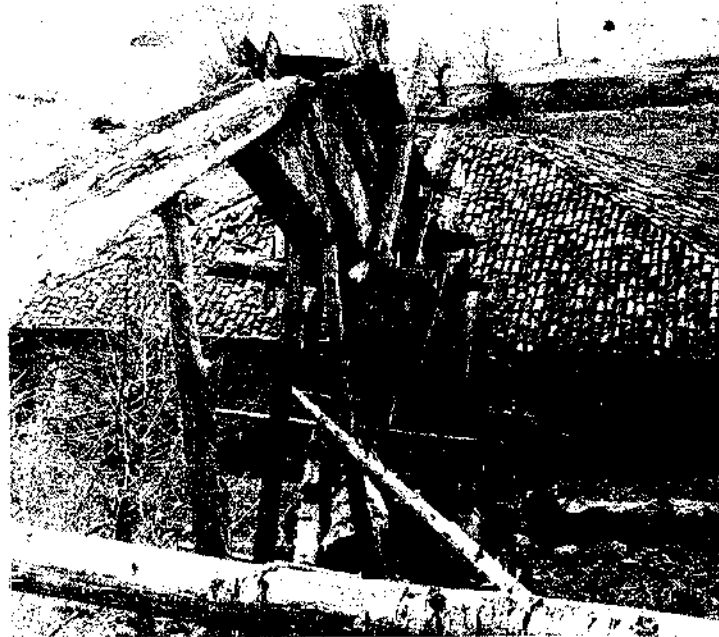

Fig. 24 The abandoned mill Number 4. Rear view.

production will increasingly prevent small rural miller to go on operating much longer. As surviving examples of this unique relic of early technology in this part of the world are abandoned one by one, there is a good chance of their complete disappearance in a near future unless measures are taken to preserve some of them for posterity.

It is, therefore, appropriate to suggest, as an extension of



Fig. 25 The abandoned mill Number 4.  
Side view.

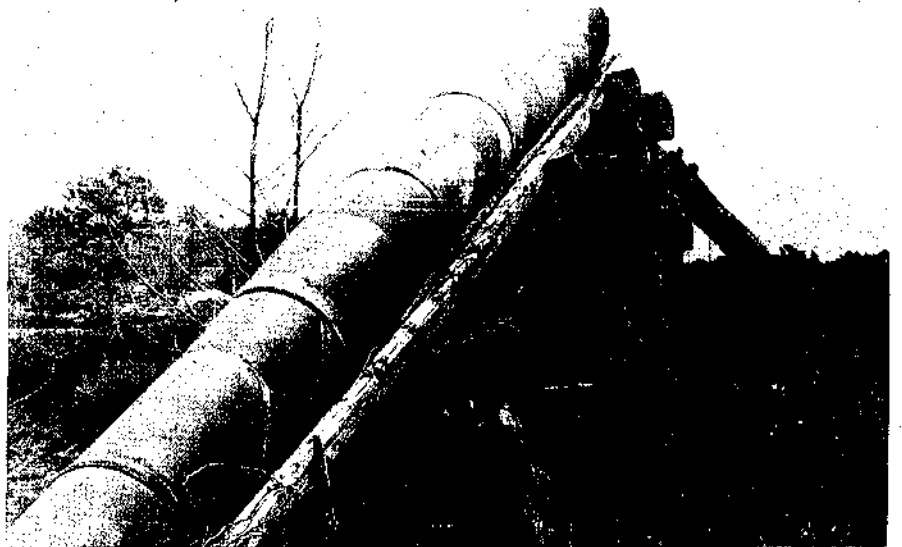

Fig. 26 The abandoned mill Number 6.  
Penstock made of discarded oil  
barrels.

this present study, either to initiate the first vernacular (technological building) conservation exercise, or to implement a case study for the new discipline of post-medieval (or industrial) archaeology in Anatolia, by a four-point plan for a conservation scheme which also entails further research and study as indicated below:

- a. To provide for a detailed field survey to produce complete visual records of all surviving examples of water-mills in each relevant region of the Anatolian Plateau;
- b. To decide on better and more interesting examples of both operational and abandoned water-mills as likely candidates to be conserved;
- c. To prepare a cost-benefit analysis on the basis of a number of water-mills to be preserved and maintained in operational

conditions-and thereby provide secure jobs for the surviving mill-wrights; and to select the mills situated in close proximity to major thorough-fares and access roads which can be easily provided with car-parking, and other facilities, and which can with ease be converted into open-air museums of early technology or industry, thereby attracting both domestic and foreign tourists in return for a nominal fee that will create a revolving fund for future maintenance and running costs; and,

- d. To prepare a master-plan of operations in following stages:
- i) Firstly to carry out an economical and effective conservation scheme for the mills and other examples of early technology;
  - ii) Then, to construct all the relevant features of an open-air museum of early technology;
  - iii) And finally, to arrange for the additional facilities for recreational purposes to be built;
- with the whole thing to be followed by the establishment of a co-ordinated administration that will be responsible for the running and maintenance of each site or open-air museum.

## ORTA ANADOLU'NUN BOLU YÖRESİNDEKİ TORBİN TORU SU DEĞİRMENLERİ ÜZERİNE BİR ARAŞTIRMA

### ÖZET

Son yıllarda gelişmekte olan Eski Teknoloji Tarihi içerisinde gıda ve un teknolojisi konulu çalışmalar önemli yer kapsar. Gıda teknolojisinin evrimi ile ilgili çalışmalar özellikle İkinci Dünya Savaşı'ndan sonra ilerlemiştir. Ancak, Akdeniz Bölgesinde su enerjisi ile çalışan değirmenler ayrıntılı olarak incelendiği halde Anadolu'da bu yönde herhangi bir çalışma bugüne dek yapılmamıştır. Bu eksikliği gidermek amacıyla Bolu yöresinde yapılan incelemelerde çok sayıda su değirmeninin belgelenmesi gerçekleştirilmiştir. Bu arada, sözü edilen değirmenlerden çoğunun yörede son yıllarda gelişen un sanayii ile yarışamayarak terkedildikleri anlaşılmıştır.

Yapılan çalışma sonucunda, Bolu yöresindeki su değirmenlerinin Roma devrinde geliştirilen ve su enerjisi ile çalışan üç tür değirmenden en eskisi olan türbin türünün örnekleri olduğu saptanmıştır. İncelenen değirmenlerden iki örnek, ahşap yapı teknolojisi, mimari özellikleri, ve çalışmaları bakımından ayrıntılı olarak ele alınmış, Avrupa'nın başka yerlerindeki örneklerle karşılaştırılmışlardır.

Yazının sonunda, Anadolu'daki bu gibi eski teknoloji örneklerinin korunması için bazı öneriler getirilmektedir.

## BIBLIOGRAPHY

- BENNETT, R. and ELTON, J. *A History of Corn Milling*. London, 1898.
- BRETT, G. Byzantine Water-Mill. *Antiquity*, Newbury, Berkshire, v. XIII, 1939, pp. 354-56 and Plate vii.
- GHILDE, V.G. Rotary Querns on the Continent and in the Mediterranean Basin. *Antiquity*, Newbury, Berkshire, v. XIII, 1943, pp. 19-26.
- CURWEN, C.E. Querns. *Antiquity*, Newbury, Berkshire, v. XI, 1937, pp. 133-51.
- CURWEN, C.E. More About Querns. *Antiquity*, Newbury, Berkshire, v. XV, 1941, pp. 15-32.
- CURWEN, C.E. The Problem of Early Water Mills. *Antiquity*, Newbury, Berkshire, v. XVIII, 1944, pp. 130-46.
- CURWEN, C.E. A Vertical Water-Mill near Salonika. *Antiquity*, Newbury, Berkshire, v. XIX, 1945, pp. 211-12 and Plates iii-iv.
- FORBES, R.J. Food and Drink. *A History of Technology*, v. II, Ed. by C. Singer et al, Oxford: The Clarendon Press, 1957, pp. 103-12.
- FORBES, R.J. Power. *A History of Technology*, v. II. Ed. by C. Singer et al Oxford: The Clarendon Press, 1957, pp. 589-622.
- HODGEN, M.T. Domesday Water Mills. *Antiquity*, Newbury, Berkshire, v. XIII, 1939, pp. 261-79.
- HODGES, H. *Technology in the Ancient World*. New York : Alfred A. Knopf, 1970.
- LINDET, C. Les origines du moulin à grains. *Revue archéologique*, Paris, 1899 et 1900, t. II et t. I.
- SINGER, C., HOLMYARD, E. J., HALL, A.R. and WILLIAMS, T.I. (Eds.). *A History of Technology, The Mediterranean Civilizations and The Middle Ages*. v. II, Oxford: The Clarendon Press, 1957.
- WILLIAMSON, K. Horizontal Water-mills of the Faeroe Island. *Antiquity*, Newbury, Berkshire v. XX, 1946, pp. 83-91.
- WULFF, H.E. *The Traditional Crafts of Persia*. London: MIT Press, 1966.

